

## Copper free aluminum alloy directional control spool valves - DP serie

Valvole di controllo a cassetto in alluminio esente rame - serie DP

www.sitecna.eu

- Suitable for automation equipment to onshore, offshore, pharmaceutical, medical and food applications
- Full material traceability
- 3/2 or 5/2 Functions
- 1/4" (DN8mm) & 3/8", 1/2", 3/4" (DN12mm) size
- Compact sizes
- Suitable for multidirectional flow
- Provided with through-holes in the body
- Suitable for dual pressure application
- Suitable for control and instrument gases
- High flow rate for the compact size of the valve
- ATEX 2014/34/UE II 2G Ex h IIC T6/T5 Gb X
- & approved II 2D Ex h IIIC T85°C/T100°C Db X
- SIL 3 - IEC 61508 (pilot operated models)

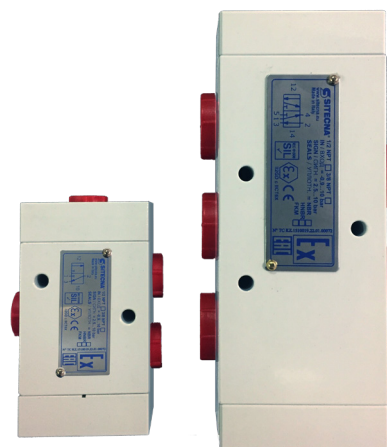

- Adatto per automazione in applicazioni marine, petrolchimiche, farmaceutiche, medicali e alimentari
- Completa rintracciabilità dei materiali
- Funzioni 3/2 e 5/2
- Taglie da 1/4" (DN 8mm) e 3/8", 1/2", 3/4" (DN12mm)
- Dimensioni compatte
- Adatte per flussi multidirezionali
- Dotate di fori passanti sul corpo

- Idonee per gas di controllo e strumentale
- Alte portate per le dimensioni compatte della valvola
- Adatte per applicazioni con doppia pressione
- ATEX 2014/34/UE II 2G Ex h IIC T6/T5 Gb X
- II 2D Ex h IIIC T85°C/T100°C Db X
- Approvato ed
- SIL 3 - IEC61508 (modelli con azionamento pneumatico)

<b>Media / Fluido</b>	<b>Compressed air, inert gases, sweet and sour gases</b>
<b>Port thread / Connessioni</b>	<b>1/4"-3/8"-1/2"-3/4" NPT</b>
<b>Working Pressure</b> Pressione di lavoro	<b>-0.9 -10 bar</b>
<b>Minimum pilot pressure</b> Pressione massima di pilotaggio	<b>2.5bar</b>
<b>Working temperature /</b> Temperatura di esercizio	<b>-20°C up to 80°C (NBR); -25°C up to 90°C (FKM); -55°C + 90°C (HNBR)</b>
<b>Orefice/Orefizio</b>	<b>dn 8 mm (1/4") - dn 12 mm (3/8", 1/2", 3/4")</b>

Air supply must be dry enough to avoid ice formation at temperatures below +2°C (+35°F).

### TYPES

- Operator: Air pilot / Return: Spring
- Operator: Air pilot / Return: Spring + internal relief
- Operator: Air pilot / Return: Pilot
- Operator: Knob push-pull/ Return: Spring
- Operator: Knob push-pull/ Return: Knob push-pull
- Operator: Air pilot / Return: Spring (manual reset)
- Operator: Pilot & manual / Return: Spring (manual res.)
- Operator: Roller Lever / Return: Spring (only 1/4")

### Modelli

- Azionamento: Pneumatico / Ritorno: Molla
- Azion.: Pneum. / Ritorno: Molla + polmonaz. interna
- Azionamento: Pneumatico / Ritorno: Pneumatico
- Azionamento: Pulsante / Ritorno: Molla
- Azionamento: Pulsante / Ritorno: Pulsante
- Azionamento: Pneumatico / Ritorno: Molla (manuale)
- Azionamento: Pneum.&manuale /Ritorno: Molla (manuale)
- Azionamento: Leva Rotella / Ritorno: Molla (solo 1/4")

BUILDING MATERIALS	Materiali costruttivi
<b>Body and end adapters in aluminum alloy with epoxy painting</b>	Corpo e adattatori terminali in alluminio esente rame con verniciatura epossidica
<b>Spool in aluminum alloy</b>	Spola in alluminio
<b>Screws and springs in stainless steel</b>	Viti e molle in acciaio inossidabile
<b>Gasket &amp; seals in elastomer</b>	Guarnizioni e tenute in elastomero

BT-DPAL/C21A

## Operator: Air pilot / Return: Spring (with or without internal relief)

Azionamento: Pneumatico / Ritorno: molla (con o senza polmonazione interna)

### 1/4" NPT Overall dimension & pneumatic diaphragm

Dimensioni di ingombro taglia 1/4" NPT

Example code:

DP3204NALNB

DP3204NALNB-IR

3/2

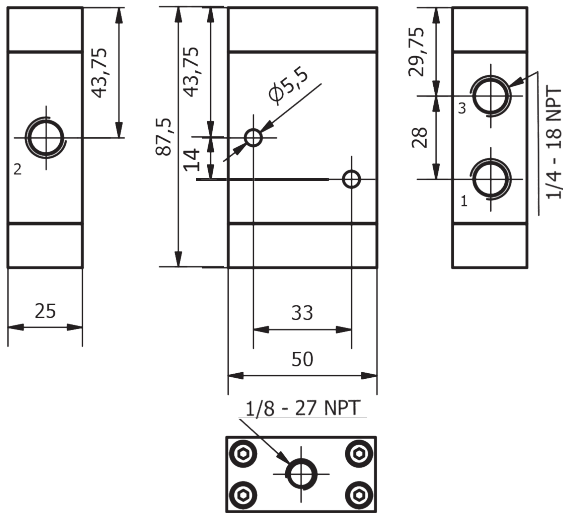
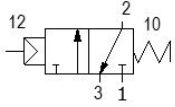

5/2

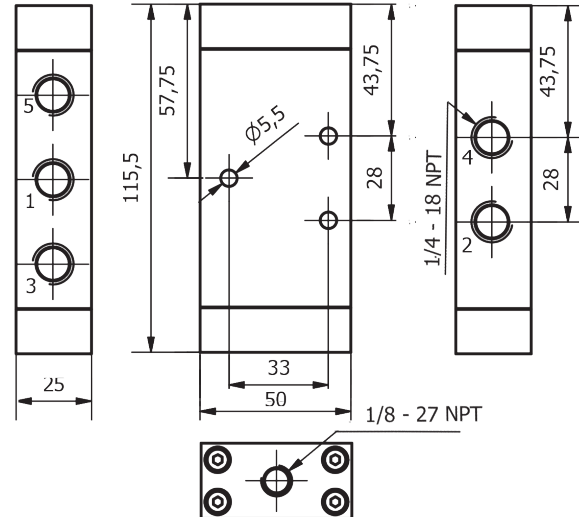
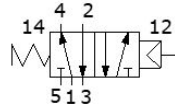

### 1/2" NPT Overall dimension & pneumatic diaphragm

Dimensioni di ingombro taglia 1/2" NPT

Example code:

DP3208NALNB

DP3208NALNB-IR

3/2

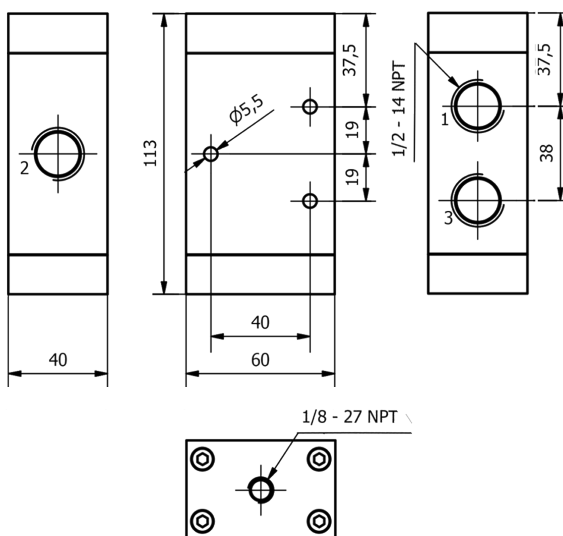
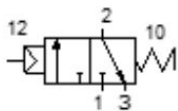

5/2

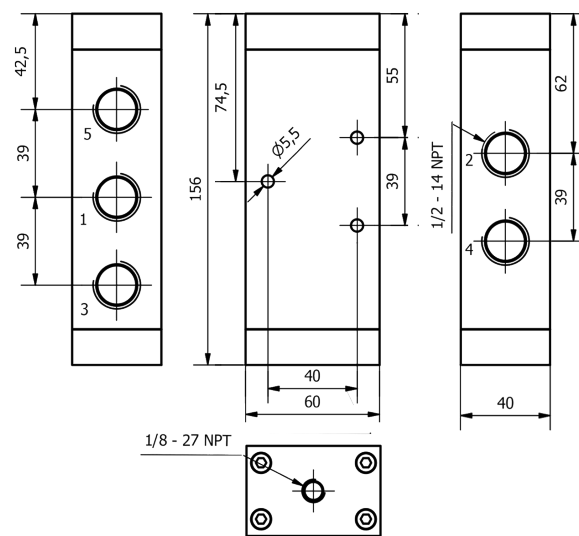
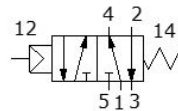

**Operator: Air pilot / Return: Pilot**

Azionamento: Pneumatico / Ritorno: pneumatico

**1/4" NPT Overall dimension & pneumatic diaphragm**

Dimensioni di ingombro taglia 1/4"NPT

**Example code:**

DPP3204NALNB

www.sitecna.eu

3/2

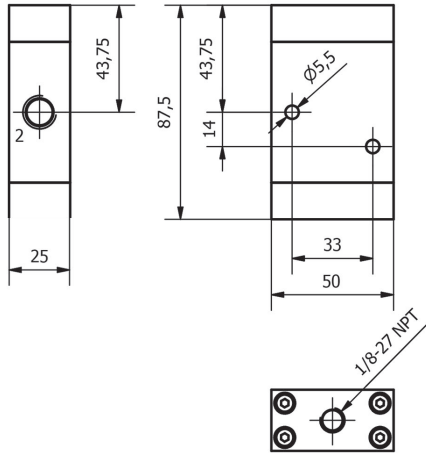
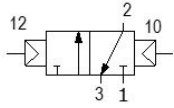

5/2

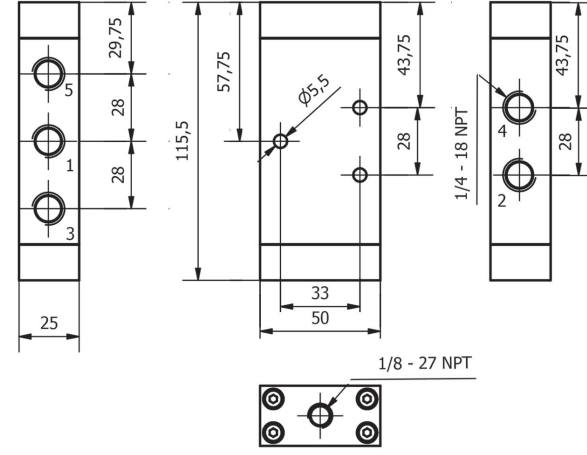
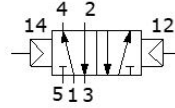

**1/2" NPT Overall dimension & pneumatic diaphragm**

Dimensioni di ingombro taglia 1/2"NPT

**Example code:**

DPP3208NALNB

3/2

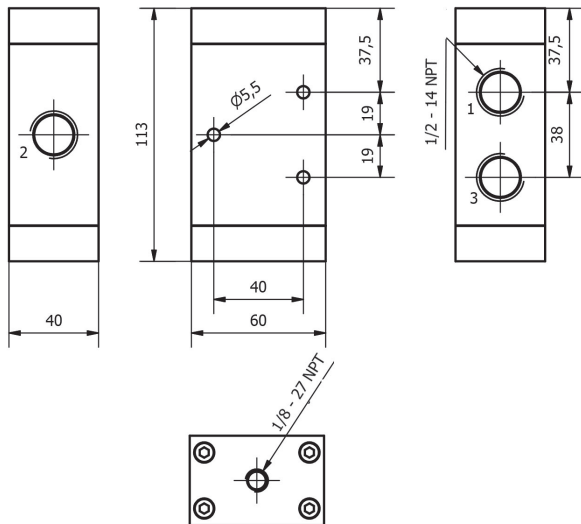
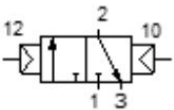

5/2

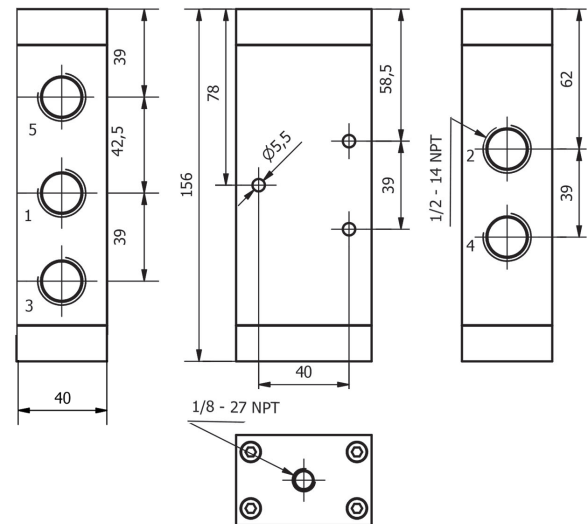
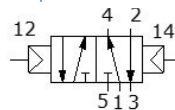

BT-DPAL/C21C

## Operator: Knob push-pull / Return: Spring

Azionamento: Pulsante palmo / Ritorno: molla

### 1/4" NPT Overall dimension & pneumatic diaphragm

Dimensioni di ingombro taglia 1/4"NPT

Example code:

DP3204NALNB-M1

3/2

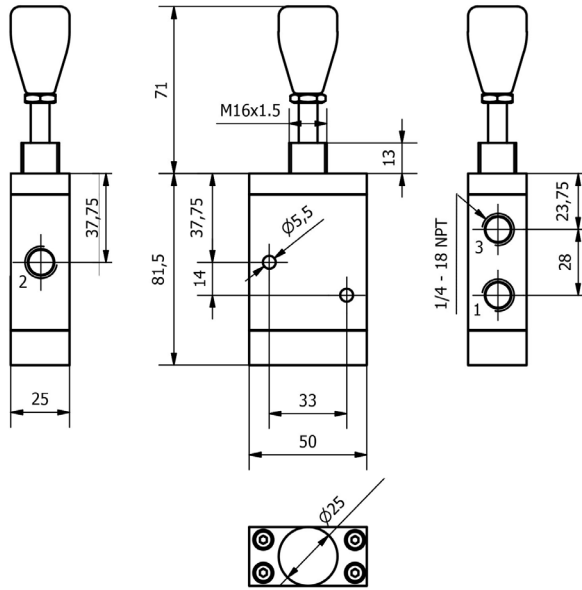
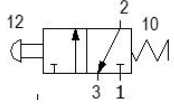

5/2

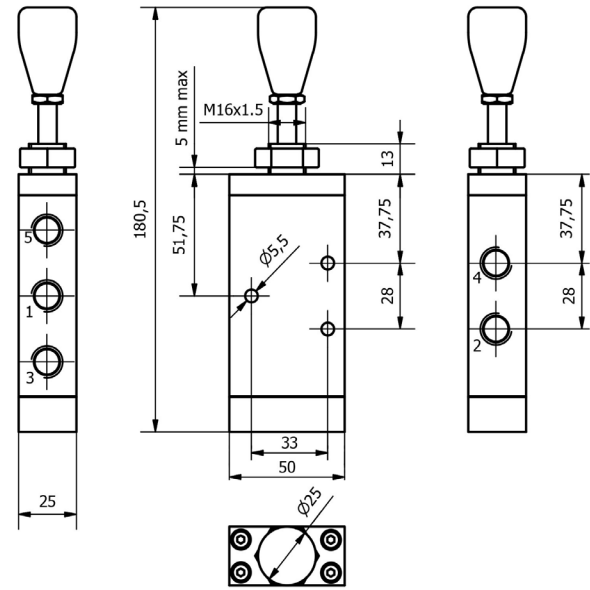
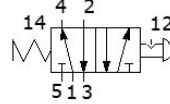

### 1/2" NPT Overall dimension & pneumatic diaphragm

Dimensioni di ingombro taglia 1/2"NPT

Example code:

DP3208NALNB-M1

3/2

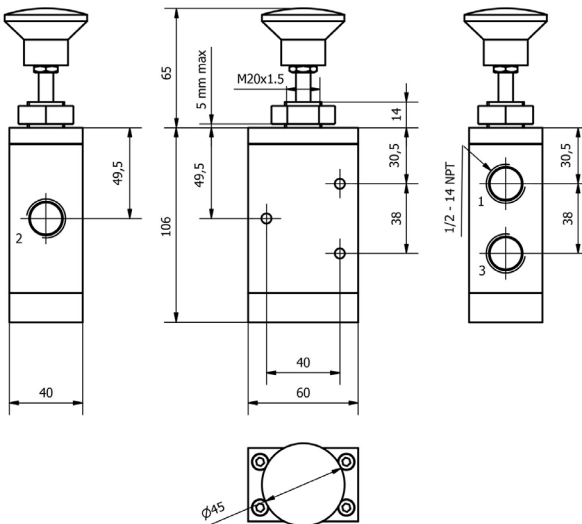
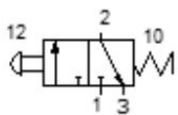

5/2

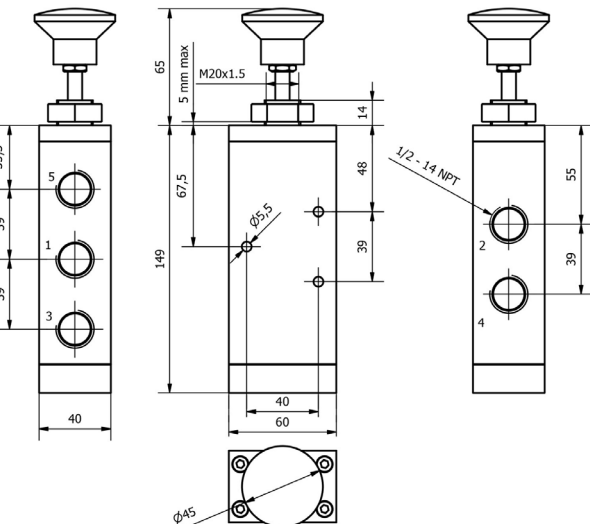
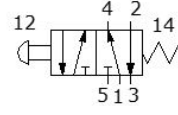

**Operator: Knob push-pull/ Return: Knob push-pull**

Azionamento: Pulsante palmo / Ritorno: pulsante palmo

**1/4" NPT Overall dimension & pneumatic diaphragm**

Dimensioni di ingombro taglia 1/4"NPT

**Example code:**

DP3204NALNB-M2

3/2

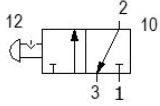

5/2

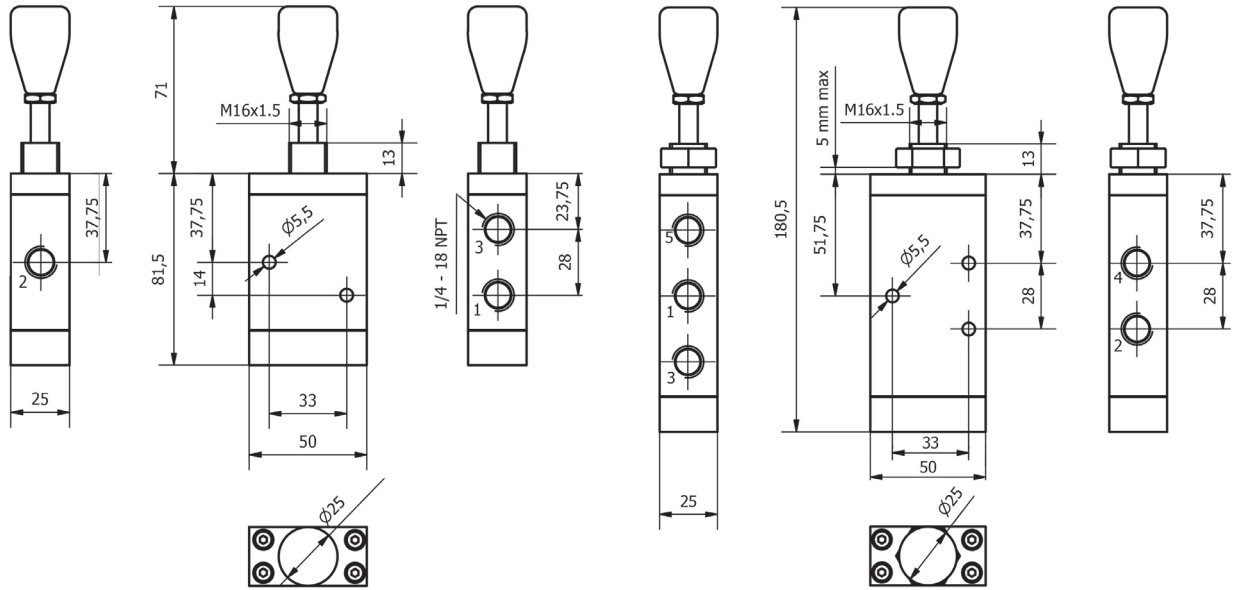
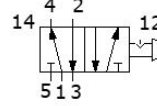

NB: Lockable version available

**1/2" NPT Overall dimension & pneumatic diaphragm**

Dimensioni di ingombro taglia 1/2"NPT

**Example code:**

DP3208NALNB-M2

3/2

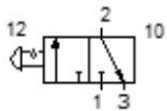

5/2

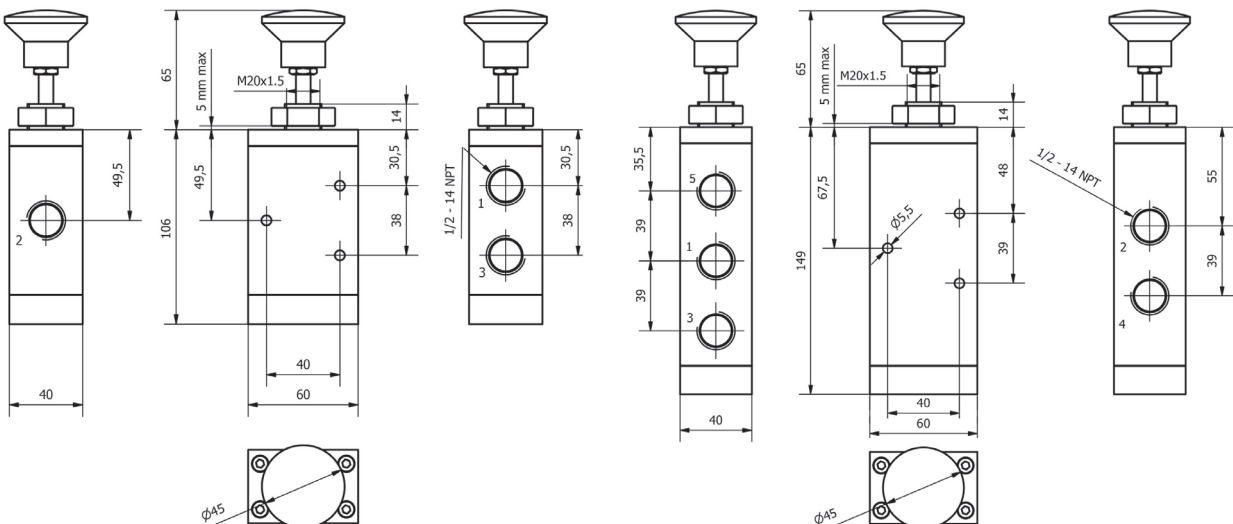
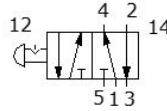

BT-DPAL/C21E

## Operator: Air pilot / Return: Spring (manual reset)

Azionamento: Pneumatico / Ritorno: molla (riarmo manuale)

### Automatic operation

Funzionamento automatico

In the absence of a pilot signal 10, the valve joins together the connections 3 and 2, shutting off the connection 1. When the pilot signal acts upon the piston and moves the spindle to the end of the stroke, the connections 1 and 2 are joined together, while connection 3 is shut off. When the signal pilot ceases, a spring brings back the spindle to its initial position and the initial configuration is restored.

In assenza di segnale-pilota 10 la valvola pone in comunicazione gli attacchi 3 e 2 intercettando la connessione 1. Quando il segnale pilota agisce sul pistone e sposta la spoletta a fine corsa, sono posti in comunicazione gli attacchi 1 e 2 mentre l'attacco 3 è intercettato. Al cessare del segnale pilota, la molla spinge la spoletta nella posizione iniziale e ripristina la configurazione di partenza.

Example code:

DP3204NALNB-RM

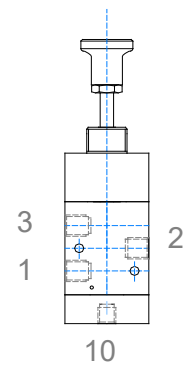

### Overall dimension

Dimensioni di ingombro

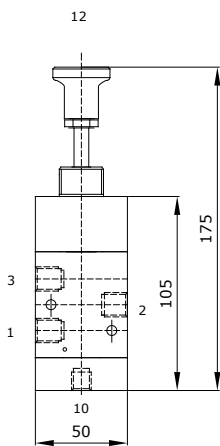

Pilot 3/2  
Pneumatico 3/2

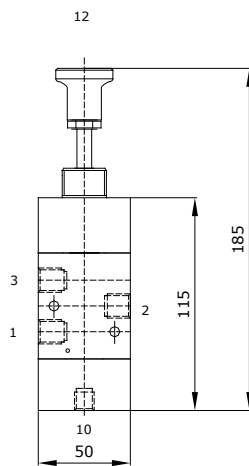

Manual Reset 3/2  
Riarmo manuale 3/2

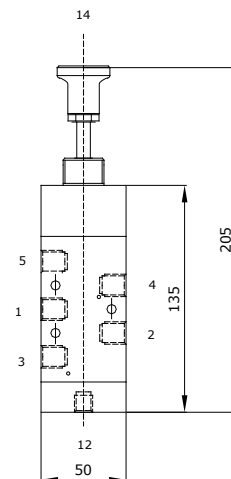

Pilot 5/2  
Pneumatico 5/2

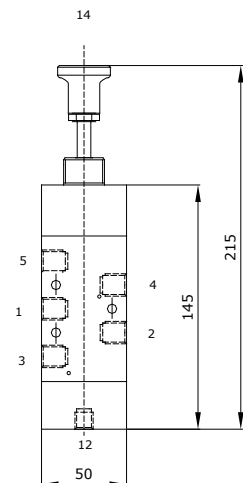

Manual Reset 5/2  
Riarmo manuale 5/2

## Operator: Air pilot & manual / Return: Spring (manual reset)

Azionamento: Pneumatico e manuale / Ritorno: molla (riarmo manuale)

The configuration is the same as in automatic operation, except that the presence of an actuating end caps with a piston prevents the action of the pilot signal without a previous manual reset by the operator. When the pilot signal is present at connection 10, the operator permits it to pass through by pulling the knob. The piston then moves the spindle to the end of the stroke, joining together the connections 1 and 2. When the pilot signal ceases, a spring brings back the spindle to its initial position, thus joining together the connections 2 and 3.

La configurazione è la stessa del funzionamento automatico ma la testata di azionamento con un pistone impedisce al segnale-pilota di agire senza l'intervento manuale dell'operatore. Quando il segnale pilota è presente all'attacco 10 e l'operatore, agendo sul pomolo, ne consente il transito, il pistone sposta la spoletta a fine corsa mettendo in comunicazione gli attacchi 1 e 2. Al cessare del segnale-pilota, la molla spinge la spoletta nella posizione iniziale mettendo in comunicazione gli attacchi 2 e 3.

Example code:

DP3204NALNB-RM1

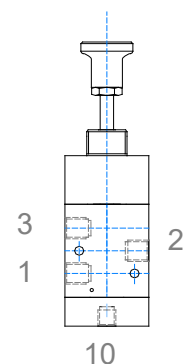

**Operator: Roller lever / Return: Spring**

Azionamento: Leva rotella / Ritorno: molla

**Overall dimension & pneumatic diaphragm**

Dimensioni di ingombro

**Example code:**

DP3204NALNB-W1

www.sitecna.eu

3/2

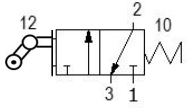

5/2

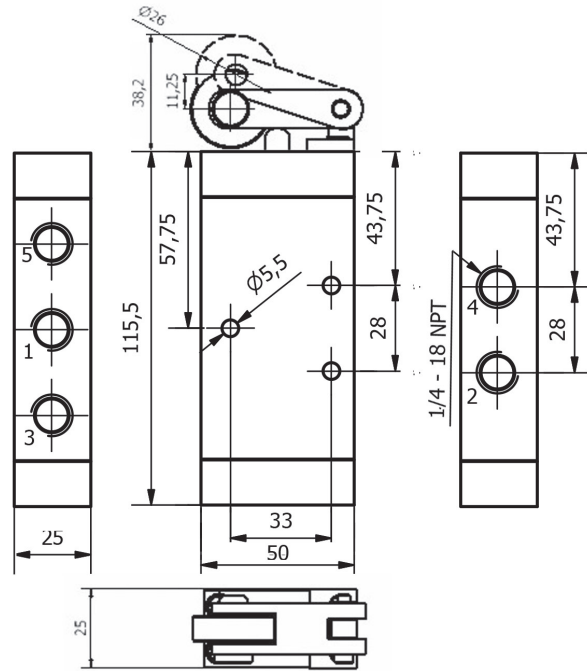
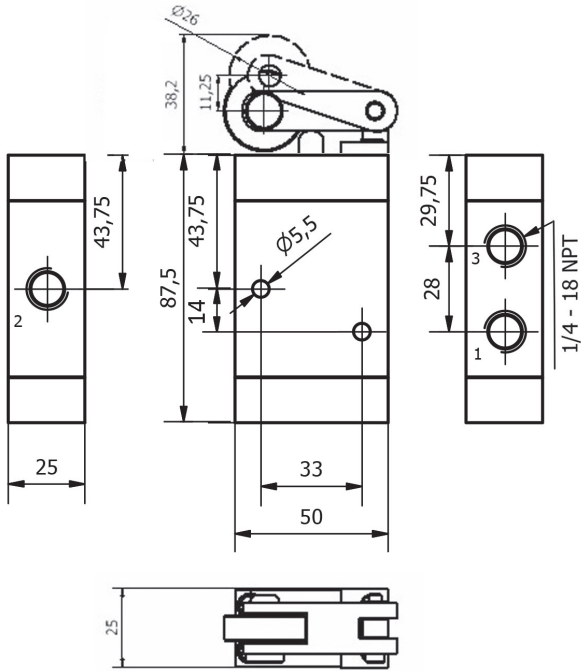
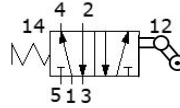

# Ordering information - Spool valves

## Come ordinare - valvole a cassetto

www.sitecna.eu

### TYPE

- DP = Operator: Air pilot / Return: Spring
- DP.....-IR = Operator: Air pilot / Return: Spring + internal relief
- DPP = Operator: Air pilot // Return: Pilot
- DP.....-M1 = Operator: Knob push-pull / Return: Spring
- DP.....-M2\* = Operator: Knob push-pull/ Return: Knob push-pull
- DP.....RM = Operator: Air pilot // Return: Spring (manual reset)
- DP.....RM1 = Operator: Air pilot / & manual / Return: Spring (manual reset)
- DP.....W1 = Operator: Roller Lever / Return: Spring (only 1/4"NPT)

DP 32 AL 04N FK -M1

### WAYS

- 32= 3 ways, 2 positions
- 52= 5 ways, 2 positions

### DIAPHRAGM & SEALS MATERIAL

- FK= FKM ( WT-25° +90°C )
- NB= NBR ( WT-20° +80°C )
- HN= HNBR (WT -55°+90°C)

### MATERIAL

- SS= 316-316L  
Stainless steel
- AL= Copper free  
aluminum alloy  
with epoxy paint

### SIZE

- 04N= 1/4" NPT
- 06N= 3/8" NPT
- 08N= 1/2" NPT
- 12N= 3/4" NPT



### CODE EXAMPLES

DP 32 AL 04N FK -M1

**1/4"NPT, aluminum alloy with epoxy paint, 3 ways 2 positions, knob operated with spring return spool valve, with FKM seals**  
Valvola a cassetto da 1/4"NPT in alluminio esente rame, 3 vie 2 posizioni, azionamento manuale, ritorno a molla, tenute in FKM

DPP 52 SS 08N HN

**1/2"NPT, SS316, 5 ways 2 positions, pilot operated with pilot return spool valve, with HNBR seals**

Valvola a cassetto da 1/2"NPT in AISI316, 5 vie 2 posizioni, doppio azionamento pneumatico, tenute in HNBR

\* Lockable version available

01-DP/20A