

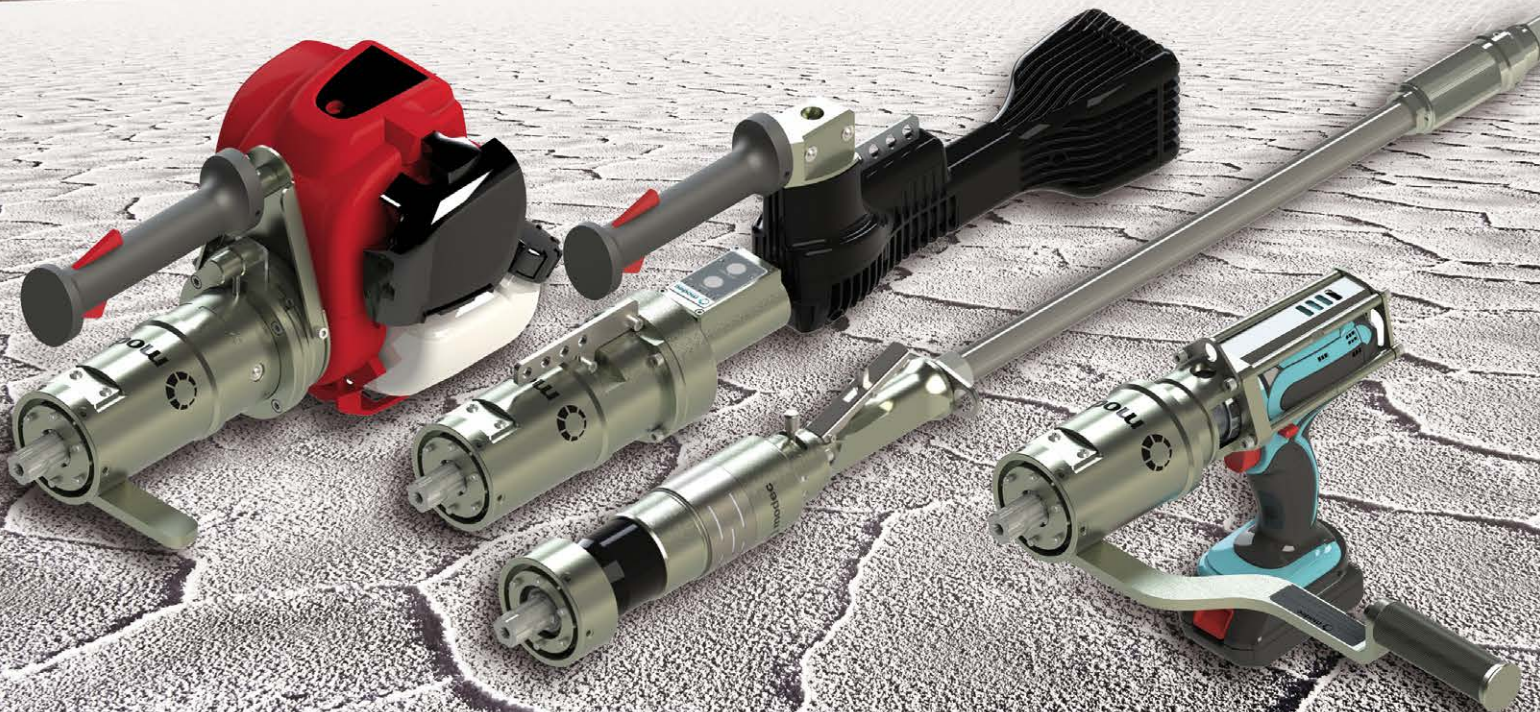

modtec
actionneurs rotatifs portables

modtec PORTABLE VALVE ACTUATORS

*efficiency vs safety ...
Why choose ?*



WELCOME TO THE **modec** WORLD



Modec motors have been used for almost 30 years for many heavy duty applications, particularly in the chemical, petrochemical and automotive industries.



Our team's technical expertise and commercial flexibility enable us to develop and provide innovative, robust and powerful motors and solutions such as valve actuators, tapping machines and nut runners in a short and reliable time frame.



Carefully assembled by our experienced workers in our factory based in Valence (South East of France), made of parts designed by our engineers and manufactured by thoroughly selected French and European suppliers, our products offer the highest quality standards.



Our technical team is at your disposal for any definition, design and realization of solution that will meet your specific needs and requirements.



Welcome to a world of innovation, expertise and flexibility.
Welcome to the modec world !



A FEW EXAMPLES OF MODEC PORTABLE ACTUATORS

DRINKING WATER SYSTEM

BEFORE...

Two operators using a traditional «T» shaped key and focusing on their effort



- Risk of car accident
- Risk of accident due to the important effort required (fall, muscular injury)
- Risk of occupational diseases
- Long operating time

AFTER...

One single operator using an electric, gas or air portable actuator and focusing on operation and safety.



- Set up time is as short as with the traditional tool
- Use of a female square drive adapter
- No effort required thanks to the torque reaction management system
- Torque and speed control for material and people protection
- Significant time saved

GAS PUMPING / STORAGE STATION

ATEX environment : Use of an air portable actuator, ATEX certified 24 valves to be actuated 4 times a week.

Time required went from 6 minutes to less than 40 seconds per valve.

Maximum torque control for valve protection by simple air pressure adjustment.

Use of a T-shaped «RD66» actuator with universal joint and female square adapter. Operator is ideally placed facing the hand wheel.

Accident, injury and occupational diseases risk reduction.



WATER TREATMENT PLANT

This portable actuator is used for a valve that is difficult to reach.

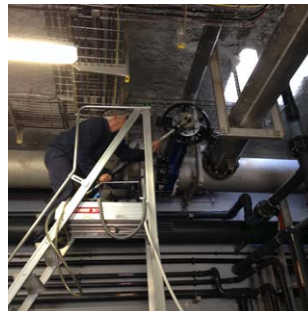

➤ Rising stem valve. Use of a «banjo» actuator with a passage in the head for the stem.

➤ «Auto centered» pods adapter for easy installation and comfortable use.

➤ Operating time decreased from 45 minutes with two operators to less than one minute with only one operator, working safely

Using the same portable actuator with different adapters, the operator can actuate all valves in the plant without modifying or pre-equipping hand wheels.



- Time saved for operators
- CAPEX reduction, since one single tool replaces many fixed actuators
- Easier, safer and faster maintenance, for optimal equipment availability
- Increased operators satisfaction

UNLOADING HATCH VALVE FOR SUGAR RAILCARS

Different energy sources may be used in that case. Air actuators can benefit from the compressed air available on train coaches.

In that case, an electric actuator with battery and revolution counter is used.



- 3 hand wheels per railcar
- Torque is not very high, speed is important
- Use of a simple reaction arm
- reduction of repetitive strain injury risk

A COMPREHENSIVE AND MODULAR RANGE

1 CHOOSE YOUR MOTOR

PNEUMATIC

HL83



No heat, spark or smoke
ATEX certification available
High torque and speed
Light & compact
Jam & blockage resistant

Maximum torque :
680 Nm (500 ft.lb)

GAS

PY68

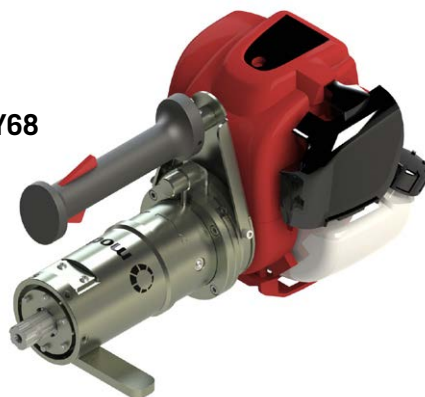

Unlimited autonomy
Ideal for remote environments

Maximum torque :
700 Nm (520 ft.lb)

ELECTRIC

JA73



Excellent autonomy
Smoke free
Easy implementation

Maximum torque :
760 Nm (560 ft.lb)

2 CHOOSE YOUR ACTUATOR'S HEAD

Unless otherwise stated, all heads are compatible with any motor

STRAIGHT

For HL83 Easy and Standard duty only



RIGHT ANGLE

RA20

Note: Using the RA20 right angle head increases torque and decreases speed by 33% and is only possible with HL83 Easy and Standard duty.



RA30



BANJO

(for rising stem valves)

Standard Duty banjo head : Multiplies the torque and divides the speed by 4



Heavy Duty banjo head : Multiplies the torque and divides the speed by 3



3 CHOOSE YOUR ADAPTOR

STANDARD FIXED FINGERS ADAPTORS



SELF-ADJUSTING AND SELF-CENTERING FINGERS ADAPTORS



SPOKE ADAPTORS FOR FLAT HANDWHEELS



SPOKE ADAPTORS FOR TAPERED HANDWHEELS



FIXED UNIVERSAL ADAPTORS

(To be installed on the hand wheel)



SQUARE DRIVES FOR STANDARD SOCKETS



4 CHOOSE YOUR TORQUE REACTION MANAGEMENT SYSTEM

TORQUE REACTION ARM

(simple or double)



TELESCOPIC BIPOD



STAND FOR BURIED VALVES



ARTICULATED REACTION ARMS

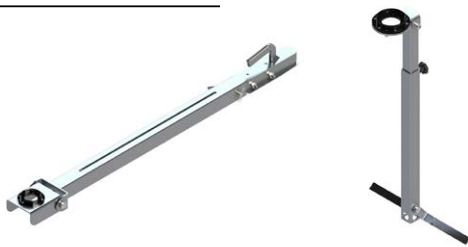

FIXED FLANGES

(to be installed on the valve)

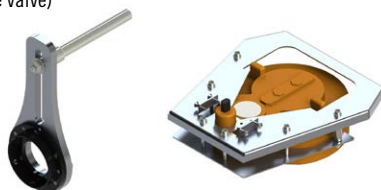

5 CHOOSE YOUR OPTIONS AND ACCESSORIES

REVOLUTION COUNTER

Digital display
Two ways rev. counter +
cumul and speed.
Memory

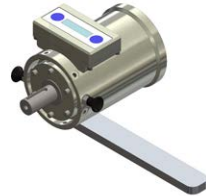

TORQUE LIMITER

Mechanical torque
limiter, manual re-engage
Adjustable torque limit



EXTENSION BARS AND UNIVERSAL JOINT

200 / 400 / 600 mm
(7.9 / 15.7 / 23.6 in)

Telescopic « Tee-key » for buried
valves

Universal joints available



TRANSPORTATION AND STORAGE CASES

Protection case for
transport and storage
Convenient and sturdy
with foam prints inside



BATTERIES

Long-life battery
Backpack



«KIT BOX»

Complete and smart metal case
for professional use





REDUCTION RATIO

(1 to 3 digits)
see table overleaf

H L 8 3 X X X X X X

E = Easy duty
S = Standard duty
H = Heavy duty

OPTION

(2 digits)
see table overleaf

modtec pneumatic portable valve actuators are the most **compact, light** and **powerful**. They offer a wide choice in terms of power and **can be used in all environments**, even the very difficult ones.

You can have them **ATEX II 2 GD c IIC T6 to T4** certified, they can go to stall and they don't generate heat, sparks or smoke.

LAYOUT

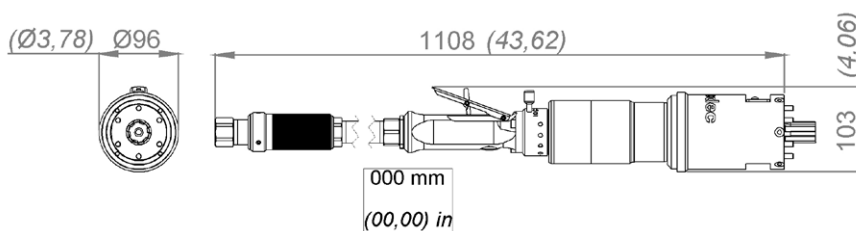
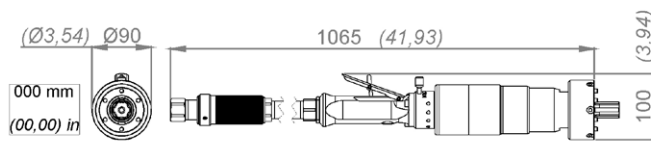
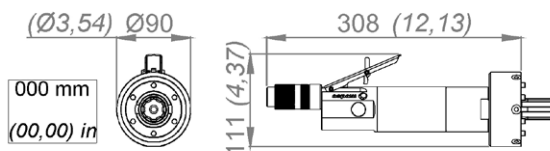

LAYOUT	Weight kg (lb)
HL83E	2,2 (4,9)
HL83S	6,5 (14,3)
HL83H	8,4 (18,5)

Watt → Horse power

W x 0,001341 = cv

Newton meter → Foot pound

Nm x 0,7376 = lb.ft

Millimeter → inch

mm x 0,03937 = in

Kv → Cv

Kv x 0,07 = Cv

Bar → pound / square inch

Bar x 14,5 = psi

Normo liter / minute → Standard cube feet / minute

NL / min x 0,03531 = scfm

Kilogramme → Pound

Kg x 2,205 = lb

PNEUMATIC PORTABLE VALVE ACTUATOR HL83

OPTIONS AND ACCESSORIES

OPTIONS (page 4)						
Right-angled head RA20		▶			▶	
Digital revolution counter			▶			▶
Torque limiter				▶	▶	▶
CODE	00	01	02	03	04	05

Not all options are available for all models.
See below for availability.

ACCESSORIES	Page
Drive head	5
Adaptors and interfaces	6-13
Torque reaction systems	14-16
Air management	17-18
Other accessories	19

! Check the technical data sheet to see which options and accessories are capable of withstanding the torque created by the actuator !

CONNECTION AND LUBRICATION

CONNECTION & LUBRICATION	Air consumption NI/min (scfm)	Connection	Minimum Ø for fittings mm (in)	Minimum Ø for pipes mm (in)	Lubrication Drops/min	FRL unit	SAT Box
HL83E	800 (28)	G 3/8	7,5 (0,28)	10 (0,39)	2,5	AC106	AC118
HL83S/H	2000 (71)	G 3/4	8,2 (0,32)	12 (0,47)	6	AC107	AC118

Make sure you use a good quality FRL unit (Filtration, Pressure Regulation and Lubrication), capable of filtering air at 40µm.

PERFORMANCE

Straight or with RA30	Free speed (rpm)			Max torque (Nm (lb.ft))			Starting torque (Nm (lb.ft))			Options available				
	4 bars (58 psi)	5 bars (72 psi)	6,2 bars (90 psi)	4 bars (58 psi)	5 bars (72 psi)	6,2 bars (90 psi)	4 bars (58 psi)	5 bars (72 psi)	6,2 bars (90 psi)	01	02	03	04	05
HL83E-023	500	530	560	13 (10)	17 (13)	21 (15)	10 (7)	14 (10)	17 (13)	▶				
HL83E-054	220	230	240	31 (23)	39 (29)	49 (36)	25 (18)	31 (23)	39 (29)	▶				
HL83S-035	230	250	270	100 (74)	120 (89)	145 (107)	80 (59)	96 (71)	116 (85)	▶		▶	▶	
HL83S-060	130	140	150	170 (125)	200 (150)	250 (180)	136 (100)	160 (120)	200 (150)	▶		▶	▶	
HL83H-169	46	50	54	380 (280)	450 (330)	570 (420)	304 (220)	360 (270)	450 (340)		▶	▶		▶

With RA20 right angle head	Free speed (rpm)			Max torque (Nm (lb.ft))			Starting torque (Nm (lb.ft))			Options available				
	4 bars (58 psi)	5 bars (72 psi)	6,2 bars (90 psi)	4 bars (58 psi)	5 bars (72 psi)	6,2 bars (90 psi)	4 bars (58 psi)	5 bars (72 psi)	6,2 bars (90 psi)	01	02	03	04	05
HL83E-023	380	400	420	18 (13)	22 (16)	28 (21)	14 (10)	18 (13)	22 (16)	▶				
HL83E-054	160	170	180	41 (30)	52 (38)	65 (48)	33 (24)	42 (31)	52 (38)	▶				
HL83S-035	170	180	190	120 (90)	160 (120)	190 (140)	96 (71)	130 (95)	150 (110)	▶			▶	
HL83S-060	100	105	115	220 (160)	270 (200)	330 (240)	180 (130)	220 (160)	260 (190)	▶			▶	
HL83H-169	Not available													

With banjo head BJH01	Free speed (rpm)			Max torque (Nm (lb.ft))			Starting torque (Nm (lb.ft))			Options available				
	4 bars (58 psi)	5 bars (72 psi)	6,2 bars (90 psi)	4 bars (58 psi)	5 bars (72 psi)	6,2 bars (90 psi)	4 bars (58 psi)	5 bars (72 psi)	6,2 bars (90 psi)	01	02	03	04	05
HL83E-023	120	130	140	54 (40)	65 (48)	82 (60)	52 (38)	64 (47)	72 (53)					
HL83E-054	52	56	60	125 (92)	150 (110)	190 (140)	115 (84)	150 (110)	180 (130)	▶				
HL83S-035	57	62	67	350 (260)	430 (320)	530 (390)	280 (210)	340 (250)	420 (310)	▶				
HL83S-060	Not available													
HL83H-169	Not available													

With banjo head BJH02	Free speed (rpm)			Max torque (Nm (lb.ft))			Starting torque (Nm (lb.ft))			Options available				
	4 bars (58 psi)	5 bars (72 psi)	6,2 bars (90 psi)	4 bars (58 psi)	5 bars (72 psi)	6,2 bars (90 psi)	4 bars (58 psi)	5 bars (72 psi)	6,2 bars (90 psi)	01	02	03	04	05
HL83E-023	160	170	180	40 (30)	49 (36)	62 (46)	32 (24)	39 (29)	50 (37)	▶				
HL83E-054	70	75	80	95 (70)	115 (84)	145 (110)	76 (56)	92 (68)	115 (84)	▶				
HL83S-035	75	82	90	260 (190)	320 (240)	400 (290)	210 (155)	260 (190)	320 (240)	▶			▶	
HL83S-060	44	48	52	450 (330)	550 (400)	680 (500)	360 (270)	440 (320)	540 (400)	▶			▶	
HL83H-169	Not available													

IMPORTANT

For your comfort and safety, please carefully read the instruction manual before using the portable valve actuator.

GAS PORTABLE VALVE ACTUATORS PY68



REDUCTION RATIO

(1 to 3 digits)
see table overleaf

P Y 6 8 X X X X X X

E = Easy duty
S = Standard duty
H = Heavy duty

OPTION

(2 digits)
see table overleaf

modtec gas portable valve actuators can be used in **total autonomy** – the only limit being the available petrol supply. They are particularly suitable for use in **isolated outdoor places**.

Extremely robust, they have an **integrated clutch system which protects the operator and the equipment**, even if a valve is completely blocked.

LAYOUT

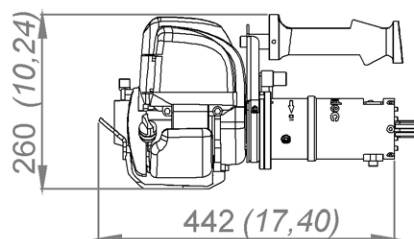
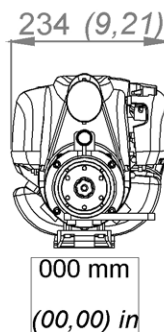

LAYOUT	Weight*(kg) (lb)
PY68E	10 (22)
PY68S	10,3 (22,7)
PY68H	10,3 (22,7)

*Empty weight
Gas tank capacity : 0.5 l (0.13 US gal)

Watt → Horse power

W x 0,001341 = cv

Newton meter → Foot pound

Nm x 0,7376 = lb.ft

Millimeter → inch

mm x 0,03937 = in

Kv → Cv

Kv x 0,07 = Cv

Bar → pound / square inch

Bar x 14,5 = psi

Normo liter / minute → Standard cube feet / minute

NL / min x 0,03531 = scfm

Kilogramme → Pound

Kg x 2,205 = lb

GAS PORTABLE VALVE ACTUATORS PY68

OPTIONS AND ACCESSORIES

OPTIONS (page 4)				
Digital revolution counter		▶		▶
Torque limiter			▶	▶
CODE	00	02	03	05

Not all options are available for all models.
See below for availability.

ACCESSORIES	Page
Drive head	5
Adaptors and interfaces	6-13
Torque reaction systems	14-16
Other accessories	19

! Check the technical data sheet to see which options and accessories are capable of withstanding the torque created by the actuator !

PERFORMANCE

Straight or with RA30	Free speed (rpm)	Max torque (Nm (lb.ft))	Starting torque (Nm (lb.ft))	Options available		
				02	03	05
PY68E-031	305	55 (41)	41 (30)	▶	▶	▶
PY68S-087	100	140 (100)	115 (85)	▶	▶	▶
PY68S-148	63	230 (170)	195 (145)	▶	▶	▶
PY68H-293	32	470 (350)	385 (285)	▶	▶	▶

With banjo head BJH01	Free speed (rpm)	Max torque (Nm (lb.ft))	Starting torque (Nm (lb.ft))	Options available		
				02	03	05
PY68E-031	75	220 (160)	160 (120)	▶	▶	▶
PY68S-087	27	550 (400)	460 (340)	▶	▶	▶
PY68S-148	Not available					
PY68H-293	Not available					

With banjo head BJH02	Free speed (rpm)	Max torque (Nm (lb.ft))	Starting torque (Nm (lb.ft))	Options available		
				02	03	05
PY68E-031	100	165 (120)	120 (90)	▶	▶	▶
PY68S-087	36	410 (300)	345 (255)	▶	▶	▶
PY68S-148	21	700 (520)	585 (430)	▶	▶	▶
PY68H-293	Not available					



IMPORTANT

For your comfort and safety, please carefully read the instruction manual before using the portable valve actuator.

ELECTRIC PORTABLE VALVE ACTUATORS JA73



RAPPORT DE REDUCTION

(1 to 3 digits)
see table overleaf

J A 7 3 X X X X X X

E = Easy duty
S = Standard duty
H = Heavy duty

OPTION

(2 digits)
Vsee table overleaf

Thanks to their long life batteries, **modtec electric portable valve actuators** are able to deliver a **high power** for more than 30 minutes. This means they are not dependent on an energy source (electric plug or compressed air network) and can operate freely anywhere. Extremely robust, they have an **integrated clutch system which protects the operator and the equipment**, even if a valve is completely blocked.

The **power limiter** (available for all the Standard and Heavy duty models) and the torque limiter (available for Easy duty models) mean **you can adapt the tool to any configuration and further improve user safety**.

LAYOUT

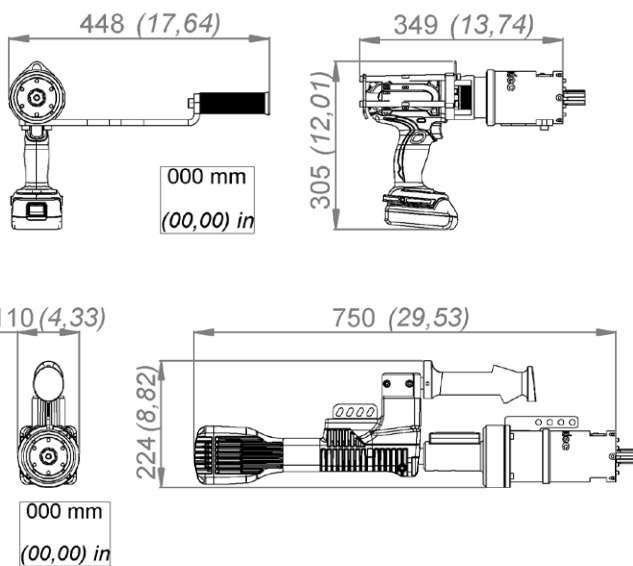

LAYOUT	Weight (kg) (lb)
JA73E	6,9 (15,2)
JA73S/E	10,1 (22,3)

Watt → Horse power

W x 0,001341 = cv

Bar → pound / square inch

Bar x 14,5 = psi

Newton meter → Foot pound

Nm x 0,7376 = lb.ft

Normo liter / minute → Standard cube feet / minute

NL / min x 0,03531 = scfm

Millimeter → inch

mm x 0,03937 = in

Kilogramme → Pound

Kg x 2,205 = lb

Kv → Cv

Kv x 0,07 = Cv

ELECTRIC PORTABLE VALVE ACTUATOR JA73

BATTERIES

Technical data	Battery 36V 4Ah	Battery 43,2V 9Ah	Batterie 43,2V 17,4Ah
Autonomy JA73E	20 min		
Autonomy JA73S		15 min	35 min
Autonomy JA73H			
Charging time	1h20	5h	8h
Weight (kg (lb))	1,3 (2,9)	4,2 (9,3)	5,9 (13)
Reference	BAT140	BAT400	BAT700

Autonomy is measured for an equivalent torque of 50% of maximum torque.



The electric portable actuators use high performance batteries for greater autonomy. The Easy duty electric actuators come with two batteries and a charger. The batteries are inserted into the tool's handle. Read the user manual for information about charging, using and transporting the batteries.

The Standard duty and Heavy duty electric actuators come without a battery – both battery and charger need to be ordered separately.

These batteries comes with a light, comfortable harness for use during transport or when using the actuator.

OPTIONS AND ACCESSORIES

OPTIONS (page 4)

Digital revolution counter		▶		▶
Torque limiter			▶	▶
CODE	00	02	03	05

Not all options are available for all models.
See below for availability.

! Check the technical data sheet to see which options and accessories are capable of withstanding the torque created by the actuator !

ACCESSORIES

ACCESSORIES	Page
Drive head	5
Adaptors and interfaces	6-13
Torque reaction systems	14-16
Other accessories	19

PERFORMANCE

Straight or with RA30	Free speed (rpm)	Max torque (Nm (lb.ft))	Starting torque (Nm (lb.ft))	Options disponibles		
				02	03	05
JA73E-005	95	15 (11)	15 (11)	▶	▶	▶
JA73E-018	26	64 (47)	64 (47)	▶	▶	▶
JA73S-077	110	150 (110)	120 (89)	▶	▶	▶
JA73S-132	63	250 (180)	200 (150)	▶	▶	▶
JA73H-309	27	590 (435)	470 (350)	▶	▶	▶

With banjo head BJH01	Free speed (rpm)	Max torque (Nm (lb.ft))	Starting torque (Nm (lb.ft))	Options disponibles		
				02	03	05
JA73E-005	24	60 (44)	60 (44)	▶	▶	▶
JA73E-018	7	250 (180)	250 (180)	▶	▶	▶
JA73S-077	27	590 (435)	470 (350)	▶	▶	▶
JA73S-132	Not available					
JA73H-309	Not available					

With banjo head BJH02	Free speed (rpm)	Max torque (Nm (lb.ft))	Starting torque (Nm (lb.ft))	Options disponibles		
				02	03	05
JA73E-005	32	45 (33)	45 (33)	▶	▶	▶
JA73E-018	9	190 (140)	190 (140)	▶	▶	▶
JA73S-077	36	440 (320)	350 (260)	▶	▶	▶
JA73S-132	21	760 (560)	600 (440)	▶	▶	▶
JA73H-309	Not available					



The JA73S and JA73H actuators can be delivered on request with a wired remote control.

Contact us for more details.

Some electric portable actuator manufacturers give torque and speed performance without reference to the length of operating time. This can suggest a high performance level when in reality the level can only be achieved for a few seconds and with significant risk of damage to the actuator's motor.

Portable actuators using a modec battery are designed and tested to deliver the stated performance level with no time limit other than the length of the battery life.

IMPORTANT

For your comfort and safety, please carefully read the instruction manual before using the portable valve actuator.

Options are built into the actuator during factory assembly and cannot be added or removed at a later stage.

▶ RIGHT ANGLE HEAD RA20



Only available for the HL83 Easy duty and Standard duty range, the **right angle head RA20** is very light and compact.

It enables the actuator to operate in small, tight spaces.

It adds a reduction ratio of 1.33 to the tool, thus **increasing the torque and reducing the speed by one third**.

Maximum torque allowed: 330Nm

▶ DIGITAL REVOLUTION-COUNTER



The **digital revolution counter** adds up the turns in one direction and subtracts them in the other direction so that the operator always knows where he is in relation to the starting point. **It also measures and indicates the rotating speed**.

It can be **easily configured** to adapt to the different actuator heads available (right angle or ring-type).

Available for the HL83H, PY68 and JA73 models.

▶ TORQUE LIMITER



The **torque limiter** for **modtec** portable valve actuators means you can disconnect the motor section from the gear box section when the torque limit is reached. No torque is thereafter applied by the actuator.

The **operator can set the torque limit** within a +/- 40% range of the original value. The torque limiter option is available for the HL83S and H models, as well as for the PY68 and JA73S and H models (the JA73E models have a torque limiter in series).

Straight or with RA30 right angle head	Reduction ratio	Minimum torque limit Nm (lb.ft)	Maximum torque limit Nm (lb.ft)
Easy duty	54	37 (27)	92 (68)
Standard duty	169	115 (85)	288 (212)
Heavy duty	258	176 (130)	440 (325)
With RA20 right angle head	Reduction ratio	Minimum torque limit Nm (lb.ft)	Maximum torque limit Nm (lb.ft)
Easy duty	72	49 (36)	122 (90)
Standard duty	225	133 (98)	333 (246)
Heavy duty	Not available		
With banjo head BJH01	Reduction ratio	Minimum torque limit Nm (lb.ft)	Maximum torque limit Nm (lb.ft)
Easy duty	216	148 (109)	368 (271)
Standard duty	Not available		
Heavy duty	Not available		
With banjo head BJH02	Reduction ratio	Minimum torque limit Nm (lb.ft)	Maximum torque limit Nm (lb.ft)
Easy duty	162	111 (82)	276 (204)
Standard duty	507	345 (254)	864 (637)
Heavy duty	Not available		

IMPORTANT

For your comfort and safety, please carefully read the instruction manual before using the portable valve actuator.

ACTUATOR'S DRIVE HEADS

The actuator heads are compatible with all **moddec** portable valve actuators.

STANDARD DUTY RING-TYPE DRIVE HEAD (“BANJO HEAD”)



Maximum allowed torque: 600 Nm (440 lb.ft)
Weight: 5kg (11 lb)

Essential for all **rising stem handwheels**, the **Standard duty banjo drive head** caters for all stems up to a **maximum diameter of 63mm (2.48”)**. It can also operate all clamping systems for handwheel and other interfaces. What’s more, it brings additional reduction which means you can **multiply the actuator’s torque by 4** and reduce the speed by the same factor. **Perfect for difficult or stiff handwheels.**

With a **maximum torque of 600 Nm (440 lb.ft)**, the Standard duty banjo head can be mounted quickly and easily on all **Easy duty actuators** and on the following **Standard duty actuators: HL83S-035, JA73S-077 and PY68S-087.**

Reference : BJH01

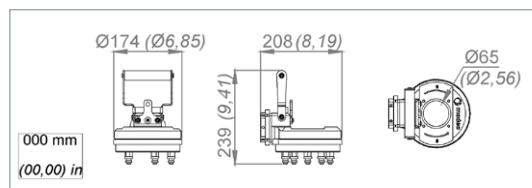

HEAVY DUTY RING-TYPE DRIVE HEAD (“BANJO HEAD”)



Maximum allowed torque: 900 Nm (660 lb.ft)
Weight: 8.6kg (19 lb)

The **Heavy duty banjo drive head** should be used for **very high torques**. It caters for **rising stems up to a maximum diameter of 70mm (2.75”)** and is compatible with all clamping systems for handwheel and other interfaces. It brings additional reduction which means you can **multiply the actuator’s torque by 3** and reduce the speed by the same factor.

With a **maximum torque of 900 Nm (660 lb.ft)**, the Heavy duty banjo head can be mounted quickly and easily on **all Easy duty and Standard duty actuators.**

Reference : BJH02

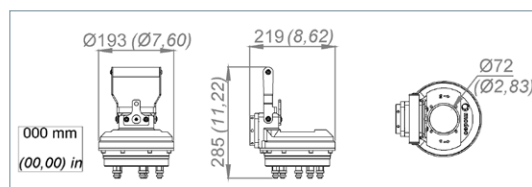

RIGHT-ANGLE DRIVE HEAD RA30



Maximum allowed torque : 630 Nm (465 lb.ft)
Weight : 5.2 kg (11.5 lb)

The RA30 right angle drive head can be positioned at 90° to the actuator providing **optimal positioning for the operator.**

It is suitable for **high torques** (up to 630 Nm (465 lb.ft)).

The right angle drive head RA30 can be mounted quickly and easily on all our actuators.

Reference : RA30

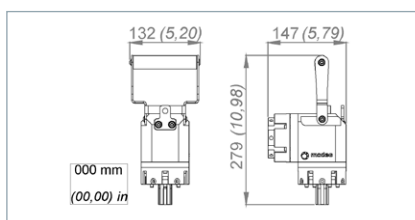

IMPORTANT

For your comfort and safety, please carefully read the instruction manual before using the portable valve actuator.

FINGERS TYPE ADAPTORS

This **exclusive patented system** is the **simplest** and **most effective** for clamping on to **flat or slightly tapered handwheels**.

No need to pre-install drive plates on the handwheel before use. The fingers type adaptors fix simply on to the portable actuator head, and can then be used to turn every handwheel that has the same number of spokes. It takes less than a minute to change the adaptor. It can also be used for rising stem valves (if used with a banjo head).

These adaptors **save a significant amount of time and money** as there's no need to buy and install a drive plate for each handwheel.

FIXED FINGERS ADAPTORS (SUAxxx)

The fixed fingers adaptors should be used for **flat or slightly tapered handwheels** (spokes at an angle $< 30^\circ$ in relation to the wheel's plane) and are composed of **removable fingers** that can be added according to the number of spokes on the handwheel you want to turn. If used with a **banjo head**, the fingers screw directly on to the head, leaving space for the **rising stem** to pass through.

If used with a **straight or right angle head**, then use a drive plate and screw the fingers on to it. In this case, you also need to **use the KPA004 interface** in order to fix the drive plate on to the actuator head (see technical sheet 11). This drive plate can also be **used directly with the banjo head**.

FOR USE WITH A BANJO HEAD :

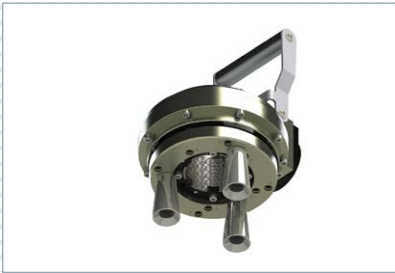

3 X SUA001 FIXED ON THE BANJO HEAD



4 X SUA001 FIXED ON THE BANJO HEAD



5 X SUA001 FIXED ON THE BANJO HEAD

FOR USE WITH A STRAIGHT OR RIGHT ANGLE HEAD :



SUA003 (1 DRIVE PLATE + 3 FINGERS)



SUA004 (1 DRIVE PLATE + 4 FINGERS)



SUA005 (1 DRIVE PLATE + 5 FINGERS)

Requires KPA004 interface with a straight or right angle drive head

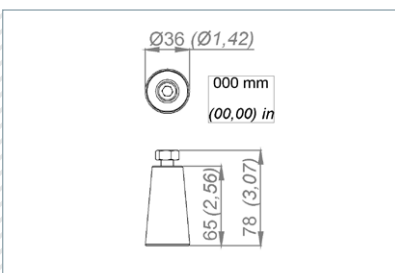

SUA001 (SINGLE FINGER)

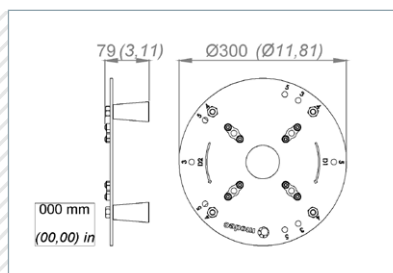

SUA3/4/5 (SET OF 1 DRIVE PLATE + FINGERS)

	Weight kg (lb)	Max torque Nm (lb.ft)
SUA001	0,3 (0,7)	3: 350 (260) 4 or 5: 800 (590)
SUA003	3,4 (7,5)	350 (260)
SUA004	3,7 (8,2)	800 (590)
SUA005	4 (8,8)	800 (590)

IMPORTANT

For your comfort and safety, please carefully read the instruction manual before using the portable valve actuator.

SELF-ADJUSTING AND SELF-CENTERING FINGERS ADAPTORS (SAxxx)



Thanks to its **patented system**, these adaptors clamp instantly on to the handwheel and **the actuator automatically centres itself giving greater ease and efficiency.**

This adaptor should be selected for **flat or slightly tapered handwheels** (spokes at an angle of $< 10^\circ$ in relation to the wheel's plane). It fixes directly on to the banjo head, and via a **KPA003, KPA004 or KPA005** interface on the standard splined shaft of the **straight and right angle actuators** (see technical sheet 11). To **avoid scratching the handwheel**, use the protector **SA103/104/105/107** (see technical sheet 11).

These adaptors **save a significant amount of time and money** as there's no need to buy and install a drive plate for each handwheel.



SA003



SA004

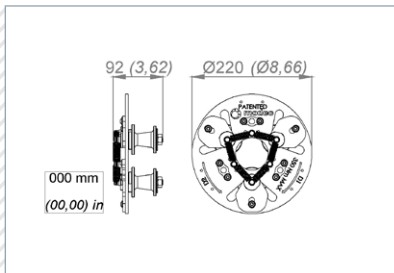

FOR 3 OR 6 SPOKES HANDWHEELS

Weight : 2,2 kg (4,9 lb)
Maximum allowed torque :
350 Nm (260 lb.ft)
Requires KPA003 interface with
a straight or right angle drive
head

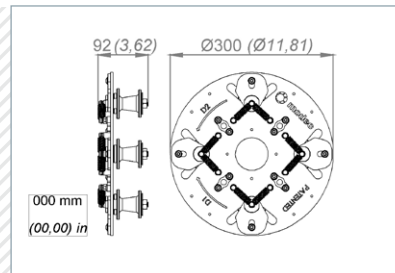

FOR 2 OR 4 SPOKES HANDWHEELS

Weight : 3,9 kg (8,6 lb)
Maximum allowed torque :
800 Nm (590 lb.ft)
Requires KPA004 interface with
a straight or right angle drive
head



SA005



SA007

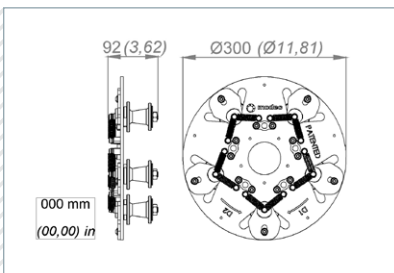

FOR 5 SPOKES HANDWHEELS

Weight : 4,1 kg (9 lb)
Maximum allowed torque :
800 Nm (590 lb.ft)
Requires KPA005 interface with
a straight or right angle drive
head

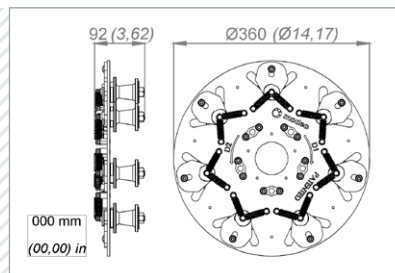

FOR 7 SPOKES HANDWHEELS

Weight : 5,9 kg (13 lb)
Maximum allowed torque :
800 Nm (590 lb.ft)
Requires KPA005 interface with
a straight or right angle drive
head

IMPORTANT

For your comfort and safety, please carefully read the instruction manual before using the portable valve actuator.

SPOKE ADAPTORS

The **spoke adaptors** clamp **solidly** and **quickly** to the handwheel and can turn in both directions, **with or without a rising stem**. It is available in two versions – one that adapts to flat or slightly tapered (< 30°) handwheels; a second for tapered handwheels (> 30°).

The adaptor has a strong hold on the handwheel and also fixes firmly to the actuator, providing complete **safety** during manoeuvres, even in difficult positions.

These adaptors **save a significant amount of time and money** as there's no need to buy and install a drive plate for each handwheel.

SPOKE ADAPTORS FOR FLAT HANDWHEELS (FSA/FSB)

These adaptors should be used for **flat or slightly tapered handwheels** (spokes at an angle < 30° in relation to the wheel's plane).

A choice of four models are available according to the **number of spokes** in the handwheel you want to turn and the **maximum diameter of the rising stem**.

These adaptors can be used with a **straight or right angle actuator** using the **KTA001** interface (for the FSA) and **KTA002** (for the FSB), and with a **banjo head** in conjunction with the **TTA001** interface (for FSA) and **TTA002** interface (for FSB) (see technical sheet 13).



FSA245 & FSB245

For 2, 4 or 5 spokes handwheels



FSA356 & FSB356

For 3, 5 or 6 spokes handwheels

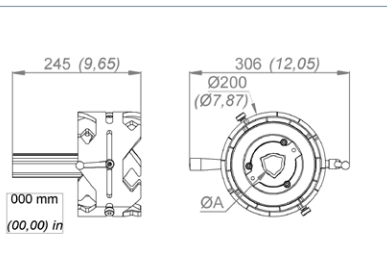

	«A» mm (in)	Weight kg (lb)
FSA	32 (1,26)	5,2 (11,5)
FSB	50 (1,97)	5,2 (11,5)

Maximum allowed torque:
800 Nm (590 lb.ft)

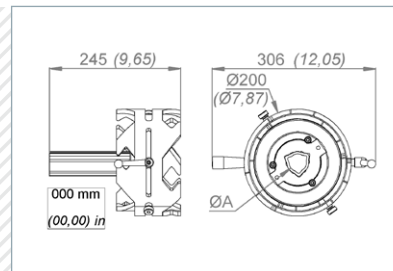

FSA adaptors require the KTA001 interface with a straight or right angle drive head and the TTA001 interface with a banjo head.

FSB adaptors require the KTA002 interface with a straight or right angle drive head and the TTA002 interface with a banjo head.

IMPORTANT

For your comfort and safety, please carefully read the instruction manual before using the portable valve actuator.

► SPOKE ADAPTORS FOR TAPERED HANDWHEELS (CSA/CSB)

These adaptors should be used for **tapered handwheels** with spokes at an angle greater than 30° in relation to the wheel's plane. A choice of six models are available according to **the number of spokes in the handwheel you want to turn and the maximum diameter of the rising stem.**

These adaptors can be used with a **straight or right angle actuator** due to the **KTA001** interface (for FSA) and **KTA002** (for FSB), and with a **banjo head** in conjunction with the **TTA001** interface (for FSA) and **TTA002** interface (for FSB) (see technical sheet 13).

These adaptors **save a significant amount of time and money** as there's no need to buy and install a drive plate for each handwheel.



CSA003 & CSB003



CSA004 & CSB004



CSA005 & CSB005

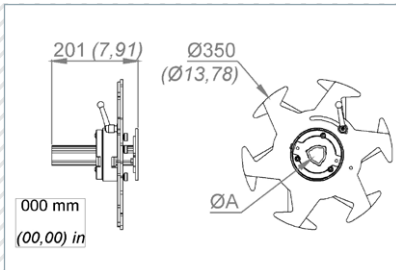

FOR 3 OR 6 SPOKES HANDWHEELS

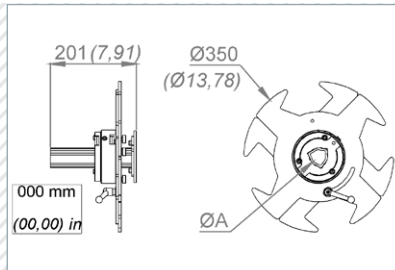

FOR 2 OR 4 SPOKES HANDWHEELS

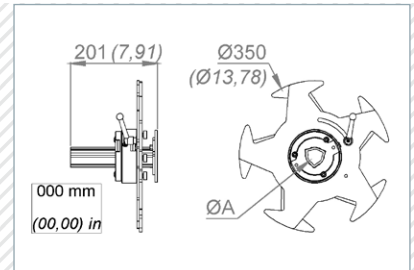

FOR 5 SPOKES HANDWHEELS

	«A» mm (in)	Weight kg (lb)
FSA	32 (1,26)	4,2 (9,3)
FSB	50 (1,97)	4,2 (9,3)

Maximum allowed torque:
800 Nm (590 lb.ft)

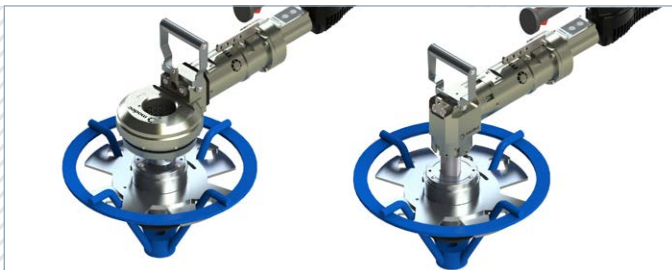

CSA adaptors require the KTA001 interface with a straight or right angle drive head and the TTA001 interface with a banjo head.

CSB adaptors require the KTA002 interface with a straight or right angle drive head and the TTA002 interface with a banjo head.

IMPORTANT

For your comfort and safety, please carefully read the instruction manual before using the portable valve actuator.

► FIXED UNIVERSAL ADAPTORS (FUAXxx)

These adaptors must be **fixed to the handwheel before use**. Thanks to their multiple “U” clamps that catch the handwheel’s spokes, they can fix on to almost every type of handwheel.

The FUA adaptor is available in 2 versions for flat or tapered handwheels: **FUA001 for flight or slightly tapered handwheels** with spokes inclined up to 30 ° in relation to the wheel’s plane; **FUA002 for tapered handwheels** with spokes inclined from 30° to 40° in relation to the wheel’s plane.

These drive plate adaptors can be used **directly on a banjo head**. To use them with a **straight or right angle head**, you need to use the **KPA004** interface (see technical sheet 11). They can also be used with **extension bars** using the interface **TTA** (see technical sheet 12).



FUA001 FOR FLAT OR SLIGHTLY TAPERED HANDWHEELS (<30°)

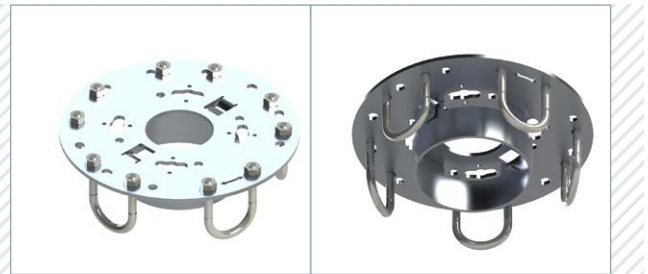

FUA002 FOR TAPERED HANDWHEELS (30° TO 40°)

	«A» mm (in)	Weight kg (lb)
FUA001	45 (1,77)	3,1 (6,8)
FUA002	65 (2,56)	3,3 (7,3)

Maximum allowed torque: 800 Nm (590 lb.ft)

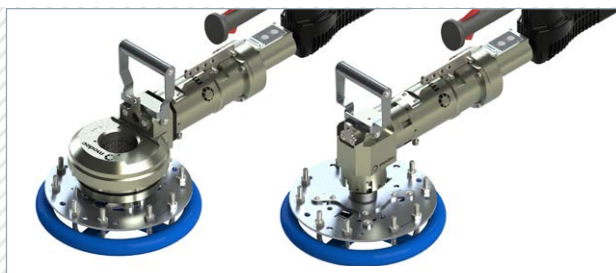
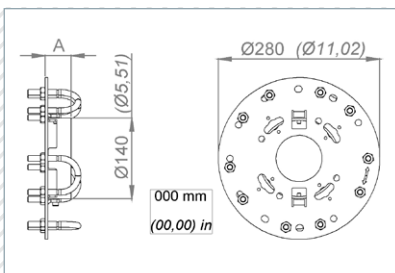

Requires KPA004 interface with a straight or right angle drive head

IMPORTANT

For your comfort and safety, please carefully read the instruction manual before using the portable valve actuator.

Thanks to the various interfaces, the adaptors can be used with any portable valve actuator and any head (straight, right angle or banjo). They also enable you to use the actuators for applications other than activating valves and on many types of interface other than handwheels.

INTERFACES FOR ADAPTORS SAXXX, SUAXXX AND FUAXXX WITHOUT A BANJO HEAD

Using the **KPA** interface, you can manipulate the **SAXxx**, **SUAXxx** and **FUAXxx** adaptors without a banjo head.

Please note, this configuration is not compatible with handwheels that have a rising stem.

The KPA interface is available in 3 versions:

KPA003 for the SA003 adaptor

KPA004 for the SA004, SUA and FUA adaptors

KPA005 for the SA005 and SA007 adaptors

Référence	Poids (kg)	Couple maxi (Nm)
KPA003	0.6 (1,3)	350 (260)
KPA004	0.8 (1,8)	800 (590)
KPA005	0.7 (1,5)	800 (590)

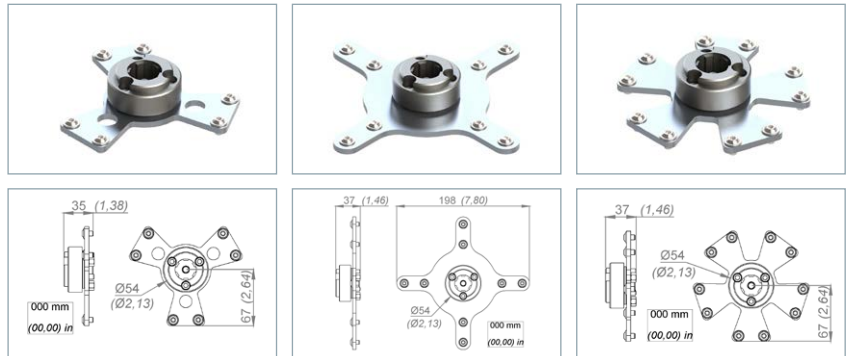

HANDWHEEL PROTECTORS FOR USE WITH SAXXX ADAPTORS

These protectors, integrated into the self-adjusting and self-centering fingers adaptors (SAXxx), are designed to **protect the handwheel from being scratched during use**. They can be built into the adaptor during assembly in the factory or added later without difficulty.

They are made from high performance polyethylene, which is anti-static and resists wear and tear.

Each adaptor has a corresponding interface:

SA103 for the SA003 adaptor

SA104 for the SA004 adaptor

SA105 for the SA005 adaptor

SA107 for the SA007 adaptor



SA103

SA104

SA105

SA107

IMPORTANT

For your comfort and safety, please carefully read the instruction manual before using the portable valve actuator.

EXTENSION BARS

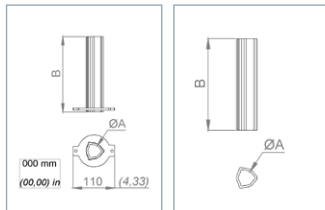

EBx01/02

EBx03/04

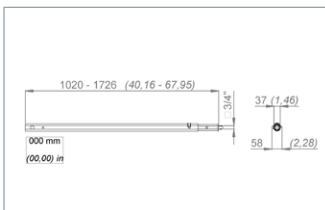

EB001

We have a wide range of **extension bars** which enable operators to move away from the handwheel or valve, notably in the case of tapered handwheels and underground / buried valves. **Light** and **robust**, they can be used on **rising stems** with two maximum diameters: 30mm or 50mm.

The **EBX01** and **EBX02** extension bars fix directly on to the **CSA**, **CSB**, **FSA** and **FSB** adaptors by one or more screw.

The **EBX03** and **EBX04** extension bars fix on to the **FUA** adaptors using the **TTA** interface.

All the extension bars can be adapted for use on the actuators using the **TTA** interface **for the banjo heads** and the **KTA** interface **for straight and right angle heads** (See technical sheet 13).

The **EB001 telescopic extension bar** is specifically adapted for manipulating **underground / buried valves**. On one end it has a square $\frac{3}{4}$ " male connector that connects to a standard socket. It can be activated either by a **straight or right angle actuator** (with the **KHA001** interface, see below), or by an actuator with a **banjo head** (using the **KHA002** interface, see below).

Reference	Weight kg (lb)	Max torque Nm (lb.ft)	"L" mm (in)	"A" mm (in)	Maxi stem Ø mm (in)
EB001	7,2 (15,9)	800 (590)	1020-1726 (40) (68)	37 (1,46)	N/A
EB201/EB203	1,0 (2,2)	800 (590)	200 (7,9)	32 (1,26)	30 (1,18)
EB401/EB403	1,9 (4,2)	800 (590)	400 (15,7)	32 (1,26)	30 (1,18)
EB601/EB603	2,8 (6,2)	800 (590)	600 (23,6)	32 (1,26)	30 (1,18)
EB202/EB204	1,3 (2,9)	800 (590)	200 (7,9)	52 (2,05)	50 (1,97)
EB402/EB404	2,5 (5,5)	800 (590)	400 (15,7)	52 (2,05)	50 (1,97)
EB602/EB604	3,7 (8,2)	800 (590)	600 (23,6)	52 (2,05)	50 (1,97)

Reference	Interface on actuator side	Interface on adaptor side	Adaptor
EB001	KHA001/002/003	Direct	CA30
EBX01	KTA001 ou TTA001	Direct	CSA / FSA
EBX02	KTA002 ou TTA002	Direct	CSB / FSB
EBX03	KTA001 ou TTA001	TTA001	FUA
EBX04	KTA002 ou TTA002	TTA002	FUA

INTERFACES FOR TELESCOPIC «TEE-KEY»

With the **KHA** interface, you can manipulate the EB001 extension bar (**telescopic «Tee-key»**).

Please note, this configuration cannot be used for handwheels with a rising stem.

The KHA interface is available in 3 versions:

KHA001 for straight and right angle actuators

KHA002 for actuators with a banjo head

KHA003 is a universal joint for straight and right angle actuators

Référence	Weight kg (lb)	Max torque Nm (lb.ft)
KHA001	0,9 (2,0)	800 (590)
KHA002	09 (2,0)	800 (590)
KHA003	2.2 (4,9)	800 (590)



KHA003

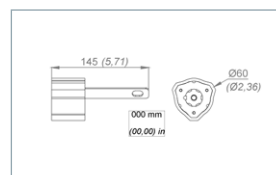

KHA001

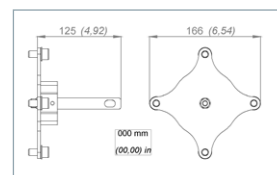

KHA002

IMPORTANT

For your comfort and safety, please carefully read the instruction manual before using the portable valve actuator.

INTERFACES FOR ADAPTORS FS, CS AND EXTENSION BARS

The **KTA** and **TTA** interfaces enable the actuators to drive the **FSA**, **FSB**, **CSA** and **CSB** adaptors, plus the **extension bars**.

The **KTA** models should be used for actuators with a straight or right angle head.

The **TTA** models fix directly on to the banjo head.



KTA (for straight or right angle heads)

TTA (for banjo heads)

Reference	Weight kg (lb)	«A» mm (in)
KTA001 : Pour FSA, CSA, EBxx1-3	0,1 (0,22)	30 (1,18)
KTA002 : Pour FSB, CSB, EBxx2-4	0,4 (0,88)	50 (1,97)

Maximum allowed torque: 800 Nm (590 lb.ft)

Reference	Weight kg (lb)	«A» mm (in)	«B» mm (in)
TTA001 : Pour FSA, CSA, EBxx1-3	0,1 (1,54)	32 (1,26)	76 (2,99)
TTA002 : Pour FSB, CSB, EBxx2-4	0,4 (1,54)	52 (2,05)	95 (3,74)

Maximum allowed torque: 800 Nm (590 lb.ft)

SQUARE DRIVES

The **KTA3/4** and **TTA3/4** interfaces can take a **3/4" square drive** which connects to **all types of socket** thereby turning all kinds of screws and bolts – this makes it possible to use your actuator for various types of applications.

The **KTA** models should be used for actuators with a straight or right angle head.

The **TTA** models fix directly on to the banjo head.

Reference	Weight kg (lb)	Max torque Nm (lb.ft)
KTA3/4	1,1 (2,43)	800 (590)
TTA3/4	1,1 (2,43)	800 (590)

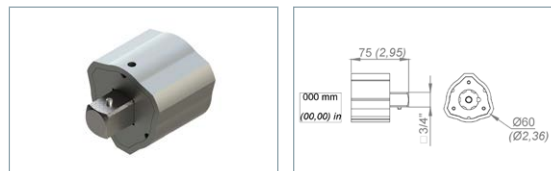

KTA3/4 (for straight or right angle heads)

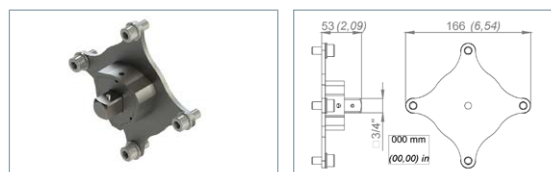

TTA3/4 (for banjo heads)

IMPORTANT

For your comfort and safety, please carefully read the instruction manual before using the portable valve actuator.

TORQUE REACTION MANAGEMENT SYSTEM

To guarantee operator **safety** and **comfort**, it's **essential** to use a **torque reaction management system**. Several types of system are available for use in different situations. Each is compatible with the whole range of actuators and adaptors because of their identical flange.

► SINGLE AND DOUBLE REACTION ARMS

Our actuators are supplied with a **torque reaction arm** which enables the torque to be controlled by a strap attached to the end of the bar and to a fixed point in the working environment. In this way, **the operator is not exposed to the torque reaction**, in particular at the end of the process.

Reference	Weight kg (lb)	Max torque Nm (lb.ft)
BR001	1,0 (2,2)	900 (660)
BR002	1,6 (3,5)	900 (660)
BR003	0,8 (1,8)	900 (660)

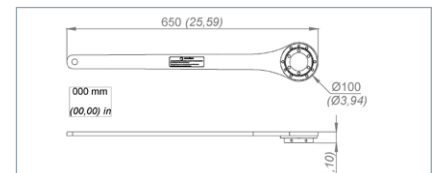

BR001

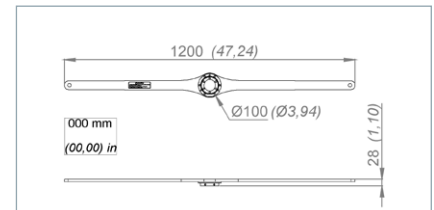

BR002

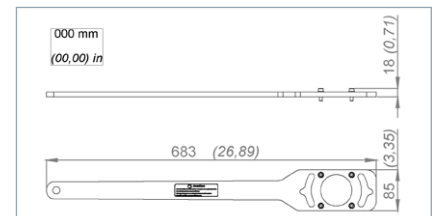
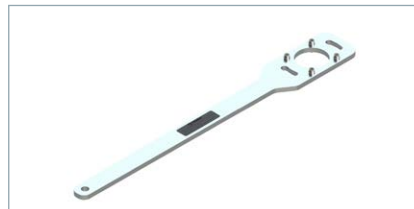

BR003

► ARTICULATED REACTION ARM FIXED TO VEHICLE TRAILER HATCH

This **telescopic metal bar** can be easily positioned between a vehicle's trailer hatch and the actuator. Ideal for **valves buried beneath roads**, or for any valve which has an upward facing handwheel.

Reference	Weight kg (lb)	Max torque Nm (lb.ft)
BA001	12.3 (27,1)	900 (660)



BA001

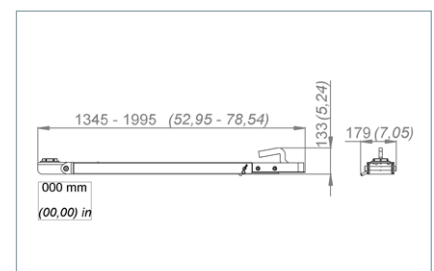

IMPORTANT

For your comfort and safety, please carefully read the instruction manual before using the portable valve actuator.

▶ FOOT HELD ARTICULATED REACTION ARM

You don't need to attach this torque reaction system to anything – By simply standing on the reaction arm, the operator doesn't need to carry the torque reaction with his arms, his own weight does the job !

Reference	Weight kg (lb)	Max torque Nm (lb.ft)
BA002	2.5 (5,5)	350 (260)

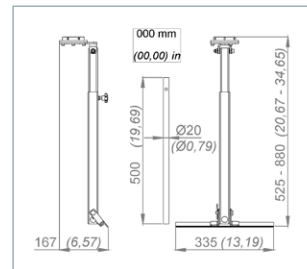

Example of use with a non accessible valve.



Example of use with a buried / underground valve.

▶ STAND FOR UNDERGROUND / BURIED VALVES

Designed for underground water distribution system valves, this stand makes the actuator easy and safe to use with a telescopic «Tee-key». Light and pliable, it's simple to transport with the two wheels, takes up minimal space and **can be erected in a couple of minutes** using just a few knurled screws.

Reference	Weight kg (lb)	Max torque Nm (lb.ft)
SE001	13.5 (29,8)	350 (260)

Once in place, the stand – not the operator - bears the load of both the torque and the weight of the actuator.

It's the perfect tool for water distribution system operators.

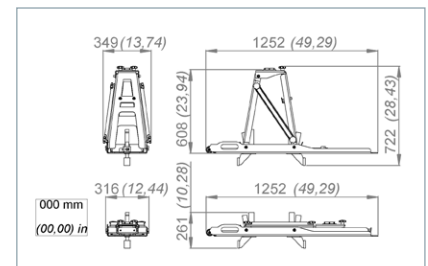

IMPORTANT

For your comfort and safety, please carefully read the instruction manual before using the portable valve actuator.

TELESCOPIC BIPOD

The bipod is **light, small, easy to use and practical**. It's adapted for use in a wide variety of situations.

With its two telescopic legs and a flange that can be placed in **any position**, it redirects the torque without any difficulty into the ground, a wall or any other fixed point.

Reference	Weight kg (lb)	Max torque Nm (lb.ft)
BP001	5.6 (12,3)	350 (260)

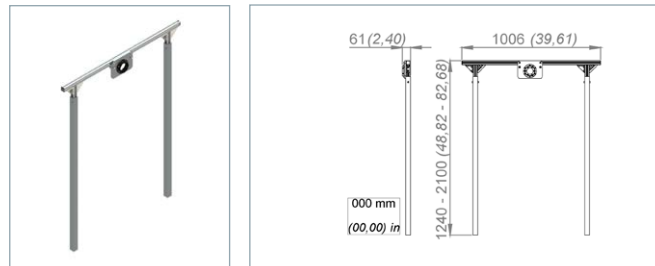

SPECIAL/ADAPTED TORQUE REACTION MANAGEMENT FLANGES

These flanges are designed to be used with a **specific valve or system**. Before using it, you need to equip the valve with a fixed system on to which the actuator can be placed. Some of them therefore require some **preliminary design** but thereafter the flange is perfectly adapted to both the system and application. This flange is particularly useful for valves and systems that do not have a hand-wheel and need activating regularly.

These flanges are **made to order** by our technical department based on the specific characteristics of your system.



Reference – made to order

IMPORTANT

For your comfort and safety, please carefully read the instruction manual before using the portable valve actuator.



ACCESSORIES

for pneumatic portable actuators 1/3

We have a range of accessories specifically for pneumatic portable actuators designed to improve user comfort as well as the protection of both operator and equipment.

AIR FILTRATION, PRESSURE REGULATION AND LUBRICATION UNITS

Pneumatic portable valve actuators (HL83) require **dry, clean** and **properly lubricated air** in order to work effectively. The FRL unit filters, dries and lubricates the compressed air, guaranteeing that the motor operates as required. It also controls the air supply pressure, which in turn controls the actuator's performance (maximum torque).

The FRL should be positioned **less than 5 metres away from the tool**. When selecting the FRL, check that it has a flow capacity suitable for the actuator's requirement.

moddec offers a complete range of FRL units that are compact, robust, adapted to the constraints of work sites and easy to connect.

Actuator reference	FRL reference	Lubrication required
HL83E	AC106	2,5 drops/min
HL83S & HL83H	AC107	6 drops/min

Self-relieving regulator. Lubrication with selective oil fog. Metal bowl with oil level viewing window.

Recommended oil type : MODEC Co-16 oil (reference AC149).

Reference	AC106	AC107
Max inlet pressure (23°C / 50°C)	16 / 10 bars 232 / 145 psi	16 / 10 bars 232 / 145 psi
Pressure gauge	0 / 12 bars 0 / 174 psi	0 / 12 bars 0 / 174 psi
Controlled pressure	0,5 / 10 bars 7 / 145 psi	0,5 / 10 bars 7 / 145 psi
Ambient temperature	0 à +50°C 0 / 122°F	0 à +50°C 0 / 122°F
Oil bowl capacity	114 cm ³ 0,004 cfm	114 cm ³ 0,004 cfm
Filtration	25 µm	25 µm
Purge system	Auto	Auto
Connection	G ¼	G ½
Dimensions	288 x 136 x 95 x 200 mm 11,3 x 5,4 x 3,7 x 7,9 in	
Weight (empty)	3,1 kg / 6,8 lb	3,5 kg / 7,7 lb

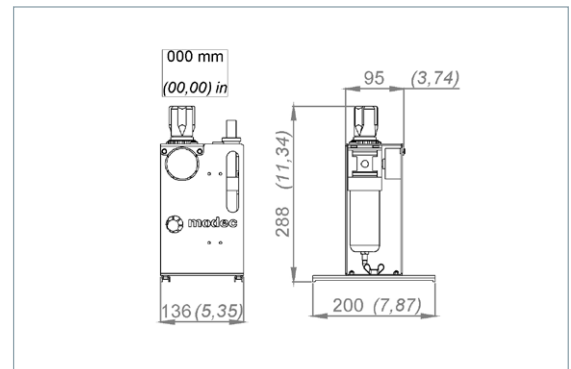

IMPORTANT

For your comfort and safety, please carefully read the instruction manual before using the portable valve actuator.



ACCESSORIES

for pneumatic portable actuators 1/3

We have a range of accessories specifically for pneumatic portable actuators designed to improve user comfort as well as the protection of both operator and equipment.

SAFETY AIR TREATMENT BOX (SAT BOX)



The **SAT Box** (Safety Air Treatment box) is a **safety device** that protects the user and the equipment.

The **SAT Box** provides numerous important safety features:

- Emergency kill switch
- Key safety lock (optional)
- Downstream automatic air-bleed
- Automatic switch off when air pressure drop detected

Reference	AC118
FRL Type	AC107
Emergency kill switch	▶
Key safety lock	Option
Automatic downstream air bleed	▶
Pressure gauge	0 / 12 bars 0 / 174 psi
Filtration	25 µm
Oil bowl capacity	114 cm ³ / 0,004 cfm
Connections	G3/4
Min & max inlet pressure	2 / 8 bars 0 / 174 psi
Dimensions	300 x 231 x 204 mm 11,8 x 9,1 x 8 in
Weight (empty)	7.6 kg / 16,8 lb
Ambient temperature	0 / +50 °C 0 / 122 °F

Those Safety devices ensure an instantaneous air bleed in the downstream circuit when the emergency kill switch is hit and/or when air supply stops. As a consequence, no residual energy may create an accidental motion after the stop. All these safety features are energized by air pressure, without any other source of energy required.

If the air feed pressure falls below 2 bars, the SAT box will automatically shut down in order to prevent the actuator inadvertently restarting if the pressure climbs back up (if the compressor stops and then restarts for example).

All of these functions are operational with the air supply pressure - there's no need for another energy source.

Finally, the SAT box integrates the FRL unit (Filtration, air pressure Regulation and Lubrication) in order to ensure that the air feed is clean and correctly lubricated.

Reference: AC118

EXHAUST COLLECTOR AND SILENCER

It is recommended to use a **silencer** with pneumatic portable actuators. It fixes to the actuator's exhaust vent and **reduces the sound level**. We have silencers of varying sizes and performance levels for different applications and constraints of use of the actuators.

> **Heavy duty exhaust silencers:** Extremely robust and compact, this stainless steel silencer reduces the noise level and protects against foreign bodies getting into the motor via the exhaust vent.

References: AC155 for Easy Duty actuators

AC156 for Standard Duty and Heavy Duty actuators

> **High flow exhaust silencer:** Constructed with a unique expansion chamber, completely free of obstruction, exhaust air softly flows to the atmosphere with significant noise and oil fog reduction, providing a clean comfortable productive work environment. Composed entirely of corrosion-resistant material for long life and maintenance-free performance, this model is especially recommended for Standard Duty and Heavy Duty actuators.

References: AC159 for Standard Duty and Heavy Duty actuators only

> **The exhaust collector** must be assembled on Standard duty and Heavy duty actuators radial exhaust to accommodate the silencer. For Easy duty actuators, the silencer can be directly fixed to the exhaust vent at the back of the motor.

IMPORTANT

For your comfort and safety, please carefully read the instruction manual before using the portable valve actuator.

ACCESSORIES

for transporting and storing portable actuators 3/3

To maintain optimum performance and durability, your pneumatic portable actuator needs to be stored in the right conditions. We have two types of box for storing and transporting actuators and their accessories.

As well as providing protection, these boxes are also ideal for transporting all the equipment to sites and minimising the risk of misplacing any parts.

▶ TRANSPORT CASES



Extremely robust, with wheels and handles, these transport and storage cases are **designed to order** so that all the equipment fits snugly into **a thick, pre-cut protective foam**.

Available in four exterior sizes, the cases are adapted to accommodate the required equipment by cutting the protective foam to measure.

Dimensions	VT001	VT002	VT003	VT004
Length mm (in)	1200 (47,2)	860 (33,9)	305 (12,0)	630 (24,8)
Height mm (in)	420 (16,5)	560 (22,0)	270 (10,6)	500 (19,7)
Width mm (in)	234 (9,2)	355 (14,0)	194 (7,6)	370 (14,6)

▶ «MODEC KIT BOX»



For **regular professional use**, the **modtec kit box** is a metal case that can hold all the equipment necessary for various operations (actuators, adaptors, torque management systems, batteries, chargers, FRL unit, air feed pipes etc). With the kit box, you can transport all the equipment to the work site **without difficulty** and **get started quickly and simply**.

The Kit box can be positioned vertically or horizontally and comes with 2x3 wheels so it can be easily moved around, even up and down stairs. The interior has compartments so the different parts can be stored easily and efficiently, and, more importantly, can be put together quickly.

In the case of a pneumatic actuator, for example, it can hold the FRL unit and an air feed pipe on a reel.

Once again, the **modtec kit box** can be modified to order and **adapted to your needs**.

References : VT005



MODEC sas

Z.I. Sirius Quatre
80 Allée René HIGONNET
F-26760 Beaumont lès Valence
France

Mail : sales@modtec.fr

Téléphone : +33 (0)4 75 40 27 15

Fax : +33 (0)4 75 40 27 36

www.modtec.fr

Your local Modtec distributor